

# Optimization - using microbatch

## Step-by-Step Instructions for Oryx6

Douglas Instruments

### Hardware Preparation

1. Clean a Douglas Vapor Batch [VB] plate with compressed air, and place it on the top left corner of the Plate Loader as shown below.
2. Place the Rinse Block to the right of the VB plate with a bottle in well five. Fill this bottle with 95% full with paraffin oil.

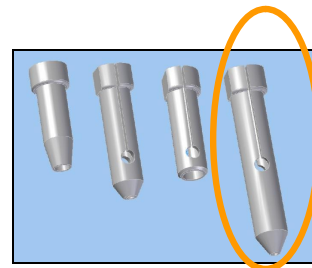
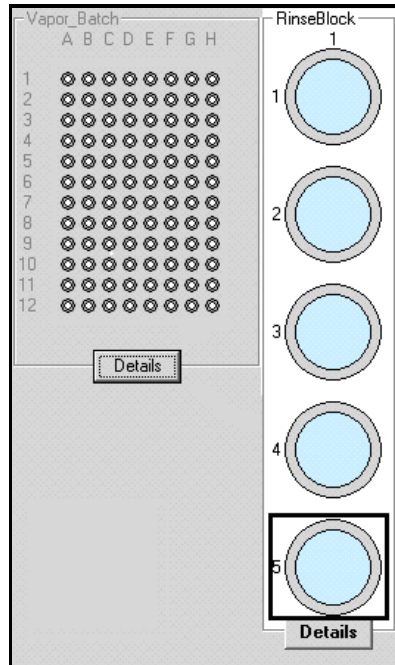

3. Connect a **5-channel Microtip** to the 5 channels of Oryx. Place the tip in the 5-channel "collet" (holder) on the left-hand Z-arm of the Plate Loader.
4. Place a disposable Gilson pipette in the right-hand V-arm of the plate loader. Flush it with air if there is any oil or solution in it.
5. Fill the ground glass syringes of the upper valves with degassed pure water and replace them.

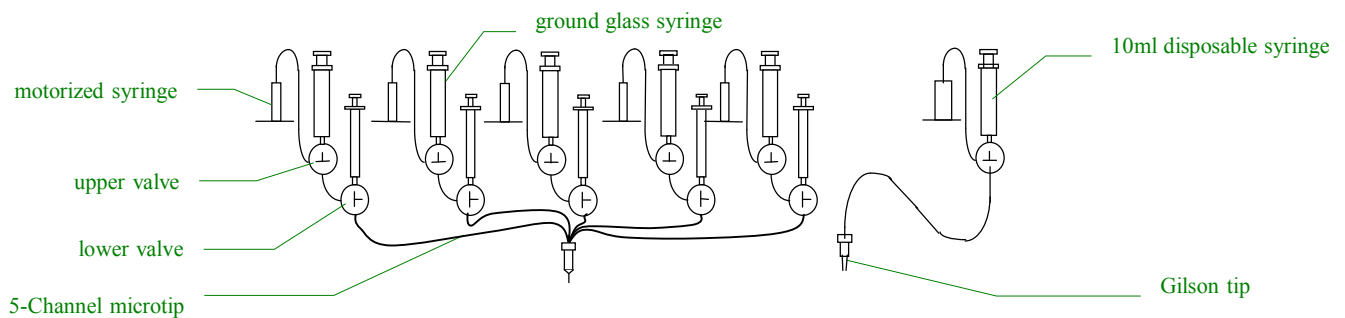

### Creating an Experiment File

6. Switch on the computer and the MCC control unit. Click on the **Start** button, **Programs, Douglas Instruments,** then **XSTEP Optimization.**
7. If you want to create a new file, select **File,** then **New Project.** Now select **File** again, then **Save As** and provide a name for the new file. Alternatively, to work with an existing file, select **Files, Open Project.**
8. If you have created a new file, or if you want to modify the names or concentrations of the stock solutions of an old file, double click in the ingredients shown on the left of the spreadsheet. Now modify the concentrations and names of the ingredients displayed. Fill in the viscosities of PEG solutions etc. As a guide, the viscosity of 40% PEG 8K is 40, while the viscosity of water is 1.
9. Click on **Experiment, Dispensing Parameters.** Specify the **Volume of the Droplets** and the **Number of Stirs.** Ensure that the **Laying On** and **Oil Dropping** options are selected. If viscous solutions such as PEG are to be dispensed, increase the **Pause** to 4 seconds.

10. Return to the spreadsheet. Each group of numbers shows the concentrations of the 6 ingredients in a well (other than water). Double click on a well to edit its values. To interpolate values between two wells highlight the appropriate block and select **Tools, Interpolate**.

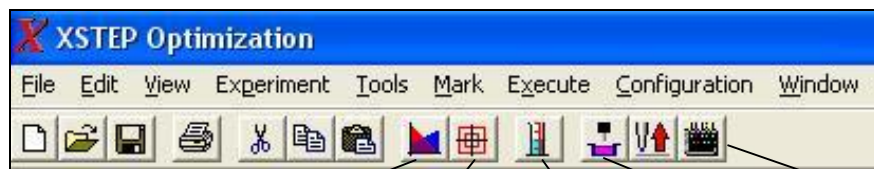

- Interpolate Selected Block    Auto Design around Selected Well    Display Volume Usage    Execute Experiment    Go to Front Panel

## Running the Experiment

11. Selecting **Experiment, Execute Experiment** executes the experiment automatically. This will take about 5 minutes for 24 wells when viscous solutions are used. On completion, you may wish to print the experiment - select **File, Print**. Alternatively you can select a well or block of wells and right click on them to **Execute selected wells**.

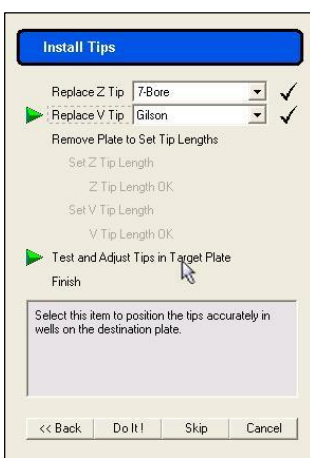

12. You will be asked to confirm that the correct tip is attached. Follow the instructions on the Wizard (show to the left) to install the correct tips and align the tip with the plate.
13. Click on the items in the Wizard to perform the action or to indicate that you have done what was requested.
14. You may skip actions in the Wizard by clicking on items further down or on 'Finish'.
15. You may repeat items in a Wizard by clicking on earlier items that are enabled.
16. Clicking 'Cancel' will abort the experiment.

## Setting the Height of the Microtip

17. If you suspect that the 7-channel Microtip is not set to the correct height select **Remove Plate to Set Tip Lengths / Set Z Tip Height**. The arm(s) will move to its lowest position. Follow the instructions on the screen:

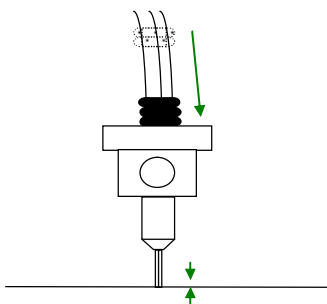

- Move one o-ring towards the tip and the other two away from the tip
- Adjust the height of the Microtip until it is just touching the table by pushing through the lower o-ring
- Mark the height by moving the top two o-rings down to the top of the collet.

18. After dispensing, add 3 ml paraffin to the VB plate. Place the plate in an incubator at the desired temperature.
19. Quit **Front Panel** before turning off your computer so that the motor positions are stored for the next use of the equipment.
20. Turn off the MCC by pressing the power button on the front of the machine.